



PH 2032

## TECHNISCHE DATEN / TECHNICAL DATA

	650 x 650 mast
Tragfähigkeit / Load capacity	2000 kg 25 Personen/25 persons
Hubgeschwindigkeit / Lifting speed	0 - 90 m/min
Förderhöhe / Lifting height	400 m
Abmessungen Fahrkorb / Car dimension	1.55 x 3.20 x 2.20 m
Abmessungen Fahrkorbtür / Car door dimension	1.5 x 2.0 m
Stromanschluss / Power supply	400 V/50 Hz

Sonderausführungen auf Anfrage! / For special application please contact factory!

Änderungen / Irrtümer vorbehalten - Changes / Errors excepted

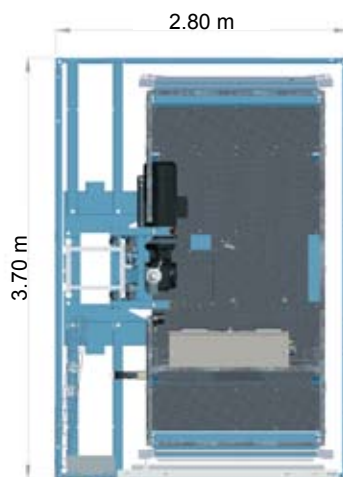
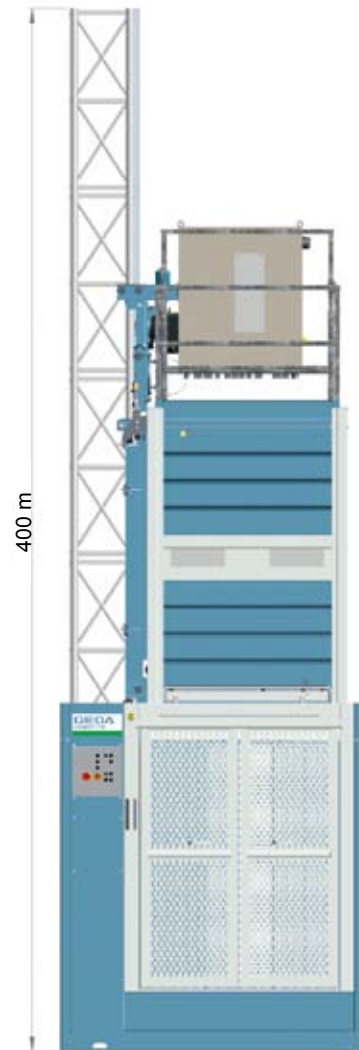

Änderungen / Irrtümer vorbehalten - Changes / Errors excepted

**GEDA-Dechentreiter  
GmbH & Co.KG**  
Mertinger Strasse 60  
D-86663 Asbach-Bäumenheim  
Phone: +49 906 9809-0  
Fax: +49 906 9809-50

**GEDA-Dechentreiter  
GmbH & Co.KG**  
Niederlassung Nordwest  
Marie-Curie-Strasse 11  
D-59192 Bergkamen-Rünthe  
Phone: +49 2389 987432  
Fax: +49 2389 987433





PH 2032

**TECHNISCHE DATEN / TECHNICAL DATA**

	<b>650 x 650 mast</b>
Tragfähigkeit / <i>Load capacity</i>	2000 kg 25 Personen/25 persons
Hubgeschwindigkeit / <i>Lifting speed</i>	0 - 90 m/min
Förderhöhe / <i>Lifting height</i>	400 m
Abmessungen Fahrkorb / <i>Car dimension</i>	1.55 x 3.20 x 2.20 m
Abmessungen Fahrkorbtür / <i>Car door dimension</i>	1.5 x 2.0 m
Stromanschluss / <i>Power supply</i>	400 V/50 Hz

Sonderausführungen auf Anfrage! / *For special application please contact factory!*Änderungen / Irrtümer vorbehalten - *Changes / Errors excepted*

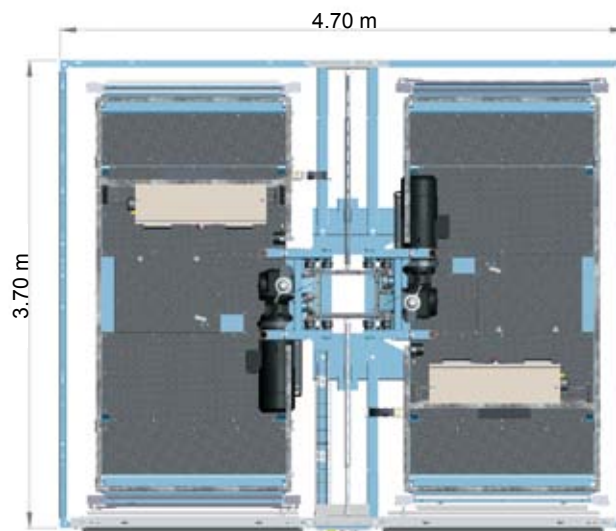
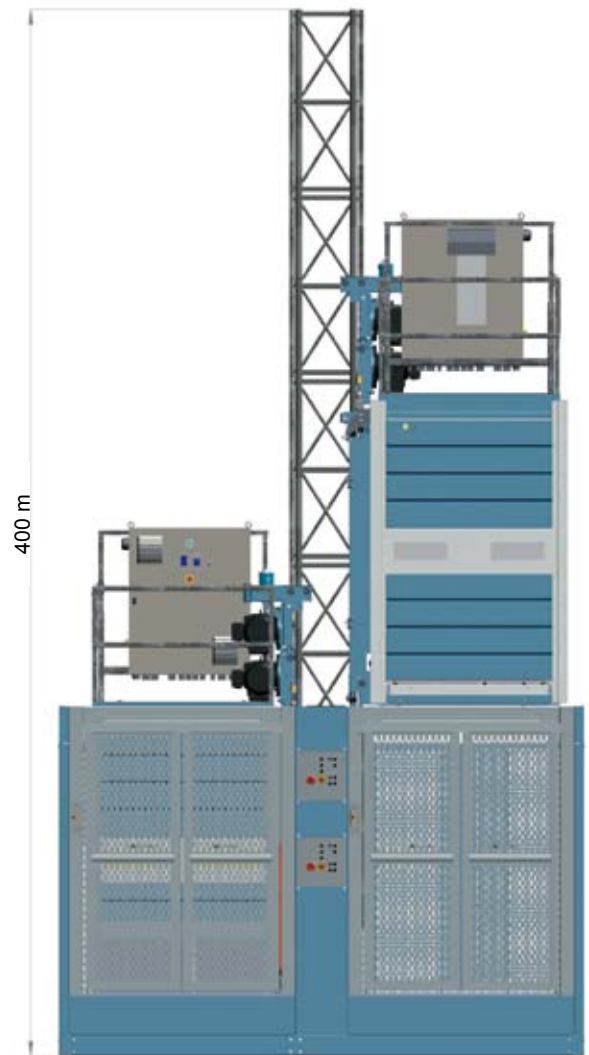

Änderungen / Irrtümer vorbehalten - Changes / Errors excepted

**GEDA-Dechentreiter  
GmbH & Co.KG**  
Mertinger Strasse 60  
D-86663 Asbach-Bäumenheim  
Phone: +49 906 9809-0  
Fax: +49 906 9809-50

**GEDA-Dechentreiter  
GmbH & Co.KG**  
Niederlassung Nordwest  
Marie-Curie-Strasse 11  
D-59192 Bergkamen-Rünthe  
Phone: +49 2389 987432  
Fax: +49 2389 987433





PH 2737

### TECHNISCHE DATEN / TECHNICAL DATA

	650 x 650 mast
Tragfähigkeit / Load capacity	2700 kg 28 Personen/28 persons
Hubgeschwindigkeit / Lifting speed	0 - 90 m/min
Förderhöhe / Lifting height	400 m
Abmessungen Fahrkorb / Car dimension	1.55 x 3.70 x 2.20 m
Abmessungen Fahrkorbtür / Car door dimension	1.5 x 2.0 m
Stromanschluss / Power supply	400 V/50 Hz

Sonderausführungen auf Anfrage! / For special application please contact factory!

Änderungen / Irrtümer vorbehalten - Changes / Errors excepted

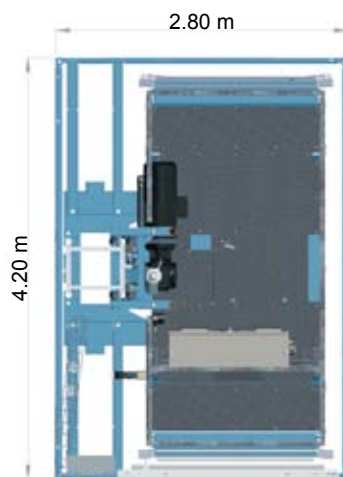
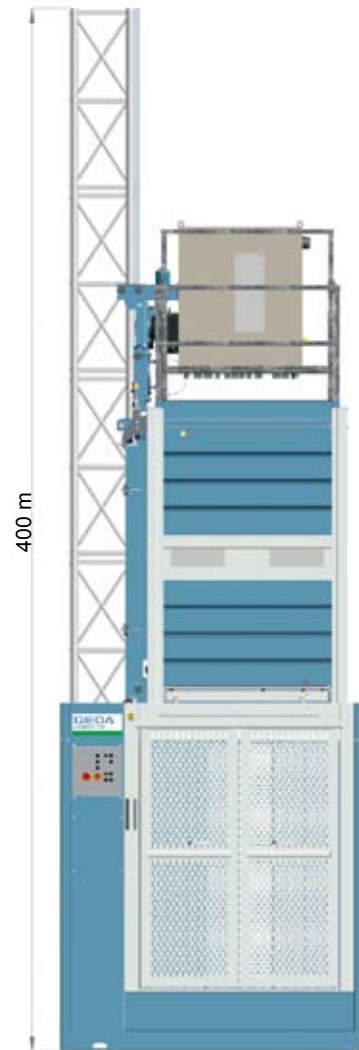

Änderungen / Irrtümer vorbehalten - Changes / Errors excepted

**GEDA-Dechentreiter  
GmbH & Co.KG**  
Mertinger Strasse 60  
D-86663 Asbach-Bäumenheim  
Phone: +49 906 9809-0  
Fax: +49 906 9809-50

**GEDA-Dechentreiter  
GmbH & Co.KG**  
Niederlassung Nordwest  
Marie-Curie-Strasse 11  
D-59192 Bergkamen-Rünthe  
Phone: +49 2389 987432  
Fax: +49 2389 987433





PH 2737

### TECHNISCHE DATEN / TECHNICAL DATA

	650 x 650 mast
Tragfähigkeit / Load capacity	2700 kg 28 Personen/28 persons
Hubgeschwindigkeit / Lifting speed	0 - 90 m/min
Förderhöhe / Lifting height	400 m
Abmessungen Fahrkorb / Car dimension	1.55 x 3.70 x 2.20 m
Abmessungen Fahrkorbtür / Car door dimension	1.5 x 2.0 m
Stromanschluss / Power supply	400 V/50 Hz

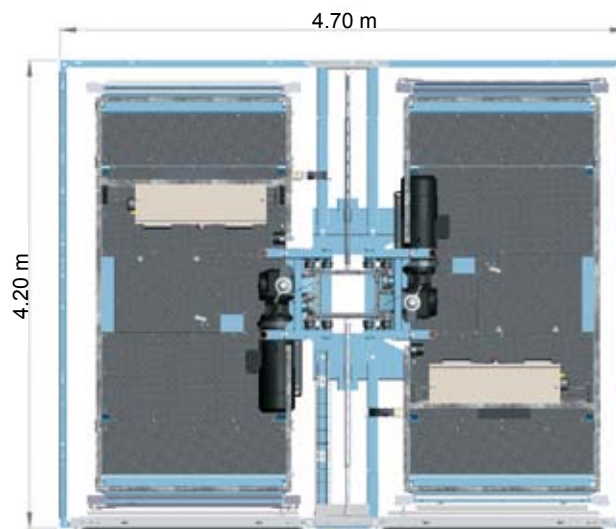
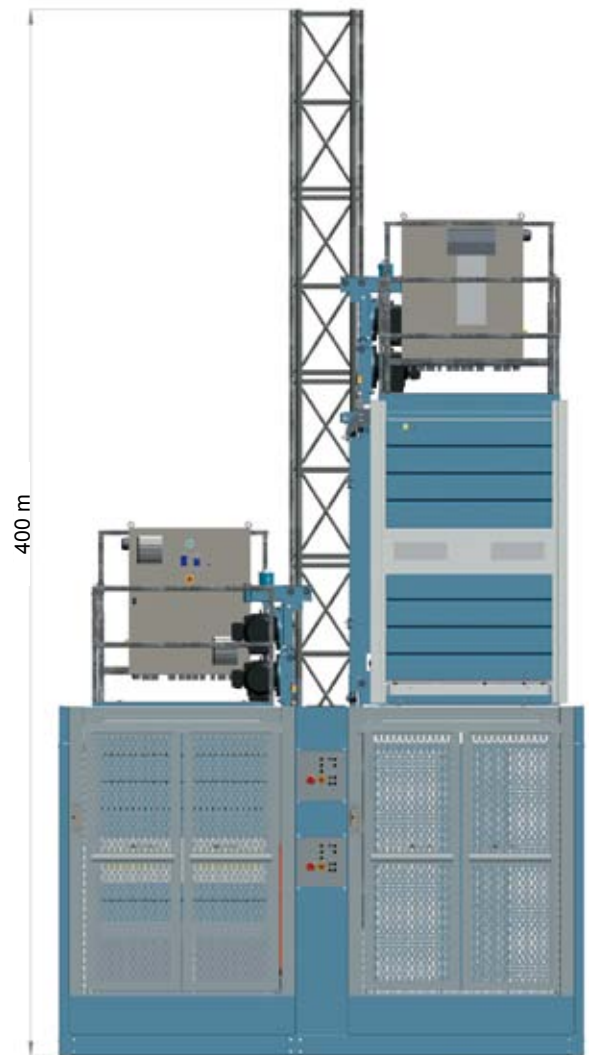

Änderungen / Irrtümer vorbehalten - Changes / Errors excepted

**GEDA-Dechentreiter  
GmbH & Co.KG**  
Mertinger Strasse 60  
D-86663 Asbach-Bäumenheim  
Phone: +49 906 9809-0  
Fax: +49 906 9809-50

**GEDA-Dechentreiter  
GmbH & Co.KG**  
Niederlassung Nordwest  
Marie-Curie-Strasse 11  
D-59192 Bergkamen-Rünthe  
Phone: +49 2389 987432  
Fax: +49 2389 987433





PH 3240

### TECHNISCHE DATEN / TECHNICAL DATA

	650 x 650 mast
Tragfähigkeit / Load capacity	3200 kg 30 Personen/30 persons
Hubgeschwindigkeit / Lifting speed	0 - 90 m/min
Förderhöhe / Lifting height	400 m
Abmessungen Fahrkorb / Car dimension	1.55 x 4.0 x 2.20 m
Abmessungen Fahrkorbtür / Car door dimension	1.5 x 2.0 m
Stromanschluss / Power supply	400 V/50 Hz

Sonderausführungen auf Anfrage! / For special application please contact factory!

Änderungen / Irrtümer vorbehalten - Changes / Errors excepted

# GEDA PH 3240 SINGLE

Personen- und Materialaufzüge / Personnel and Material Hoists

Ausgabe 05/2011/D - Edition 05/2011/GB

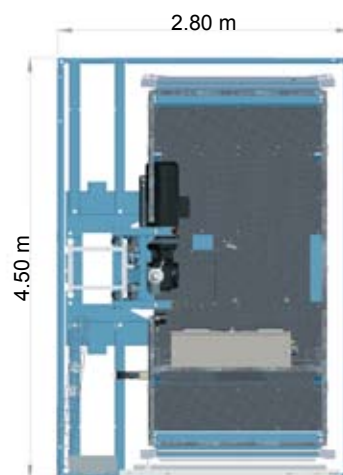
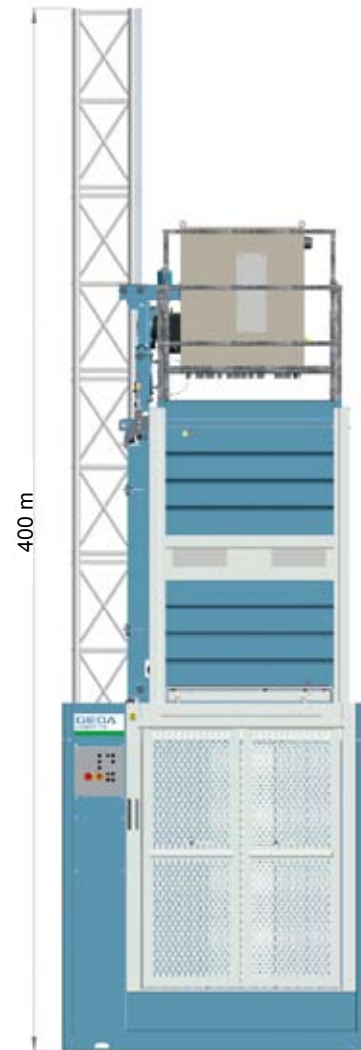

Änderungen / Irrtümer vorbehalten - Changes / Errors excepted

**GEDA-Dechentreiter  
GmbH & Co.KG**  
Mertinger Strasse 60  
D-86663 Asbach-Bäumenheim  
Phone: +49 906 9809-0  
Fax: +49 906 9809-50

**GEDA-Dechentreiter  
GmbH & Co.KG**  
Niederlassung Nordwest  
Marie-Curie-Strasse 11  
D-59192 Bergkamen-Rünthe  
Phone: +49 2389 987432  
Fax: +49 2389 987433



[info@geda.de](mailto:info@geda.de)

[www.geda.de](http://www.geda.de)



PH 3240

**TECHNISCHE DATEN / TECHNICAL DATA**

	<b>650 x 650 mast</b>
Tragfähigkeit / <i>Load capacity</i>	3200 kg 30 Personen/30 persons
Hubgeschwindigkeit / <i>Lifting speed</i>	0 - 90 m/min
Förderhöhe / <i>Lifting height</i>	400 m
Abmessungen Fahrkorb / <i>Car dimension</i>	1.55 x 4.0 x 2.20 m
Abmessungen Fahrkorbtür / <i>Car door dimension</i>	1.5 x 2.0 m
Stromanschluss / <i>Power supply</i>	400 V/50 Hz

Sonderausführungen auf Anfrage! / *For special application please contact factory!*Änderungen / Irrtümer vorbehalten - *Changes / Errors excepted*

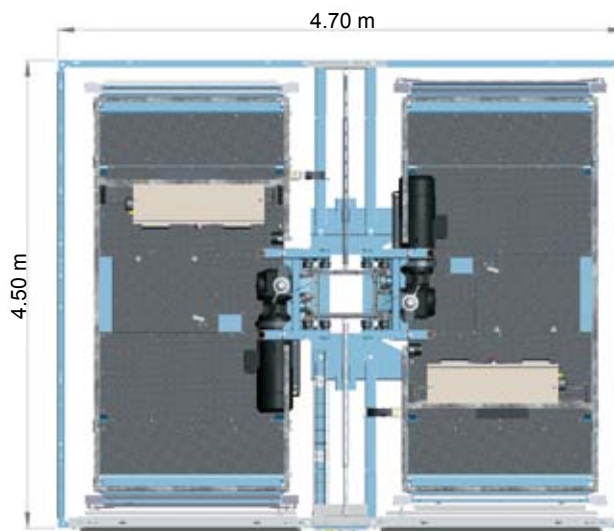
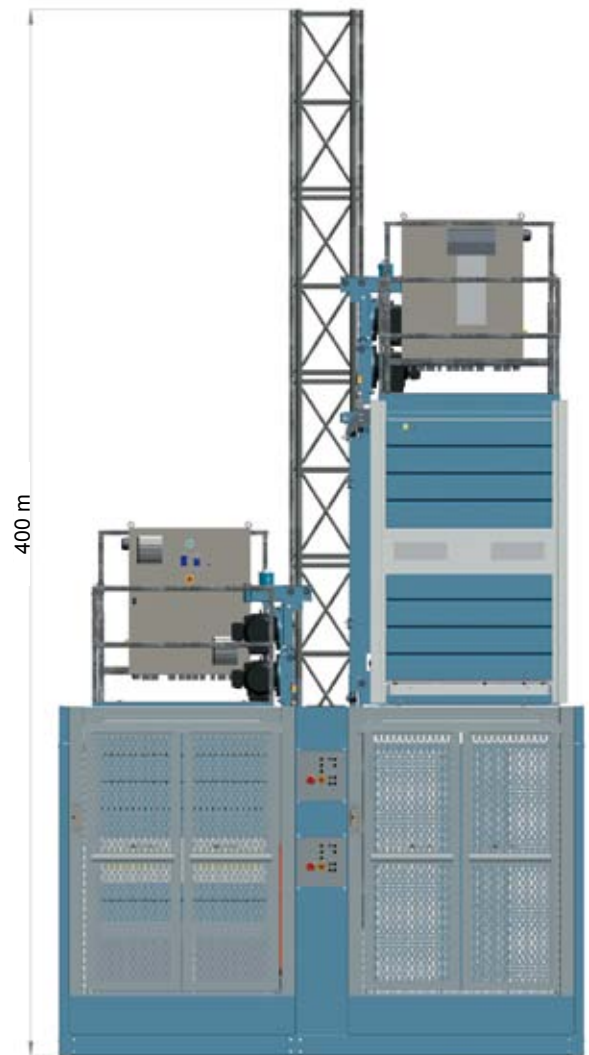

Änderungen / Irrtümer vorbehalten - Changes / Errors excepted

**GEDA-Dechentreiter  
GmbH & Co.KG**  
Mertinger Strasse 60  
D-86663 Asbach-Bäumenheim  
Phone: +49 906 9809-0  
Fax: +49 906 9809-50

**GEDA-Dechentreiter  
GmbH & Co.KG**  
Niederlassung Nordwest  
Marie-Curie-Strasse 11  
D-59192 Bergkamen-Rünthe  
Phone: +49 2389 987432  
Fax: +49 2389 987433

